

*SINGLE TUBULAR UPSWEEP ARM SPECIFICATIONS		
CATALOG NO.	ARM LENGTH (FT.)	RISE (FT.)
HPS-1-3014	4'	3'
HPS-1-3016	6'	3'
HPS-1-3018	8'	3'

POLE SPECIFICATIONS			
NO.	COMPONENT	ASTM DESIGNATION	MIN. YIELD (P.S.I)
1.	POLE SHAFT	A-595 GR. A	55,000
2.	BASE PLATE	A36	36,000
3.	ANCHOR BOLTS	F1554 GR. 55	55,000
4.	GALVANIZED HARDWARE	A153	-

POLES SHALL HAVE A POLYESTER POWDER COAT FINISH IN A STANDARD COLOR.

POLE DIMENSIONS			
POLE HGT. (FT.)	TOP DIA. (IN.)	BOTTOM DIA. (IN.)	MTG. HGT. (FT.)
27'	4.22	8.00	30'

BASE PLATE DIMENSIONS			
BOLT CIRCLE (IN.)	BASE PLATE DIM. (IN.)	BOLT HOLE (IN.)	PLATE THK. (IN.)
10.50-11.50	12.00 SQ	1.25	1.00

ANCHOR BOLT DIMENSIONS	
ANCHOR BOLT DIA. (IN.)	ANCHOR BOLT LENGTH (IN.)
1.00	40.00

ALLOWABLE WIND LOADING (SQ. FT.) PER ARM	
WIND*	EPA
100 MPH	2.0

*WITH 1.3 GUST FACTOR

SOME GEOGRAPHICAL AREAS HAVE SPECIAL WIND CONDITIONS THAT CAN CREATE WIND INDUCED VIBRATIONS CAUSING A FATIGUE PROBLEM. NO METHOD HAS YET BEEN FOUND FOR PREVENTING OR REDUCING DESTRUCTIVE LIGHTNING STRIKES. POLE FABRICATORS ARE REQUIRED TO PROVIDE PROTECTIVE LIGHTNING PROTECTION. THESE CONDITIONS ARE REQUIRED AND CANNOT BE GUARANTEED AGAINST, AND ARE THE RESPONSIBILITY OF A LOCAL SITE ENGINEER.

TITLE:
CATALOG:
DWG NO: HPS-1-3014-HPS-1-3018 SIZE: C SHEET 1 OF 1

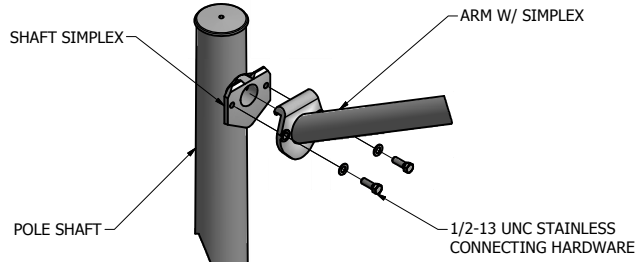
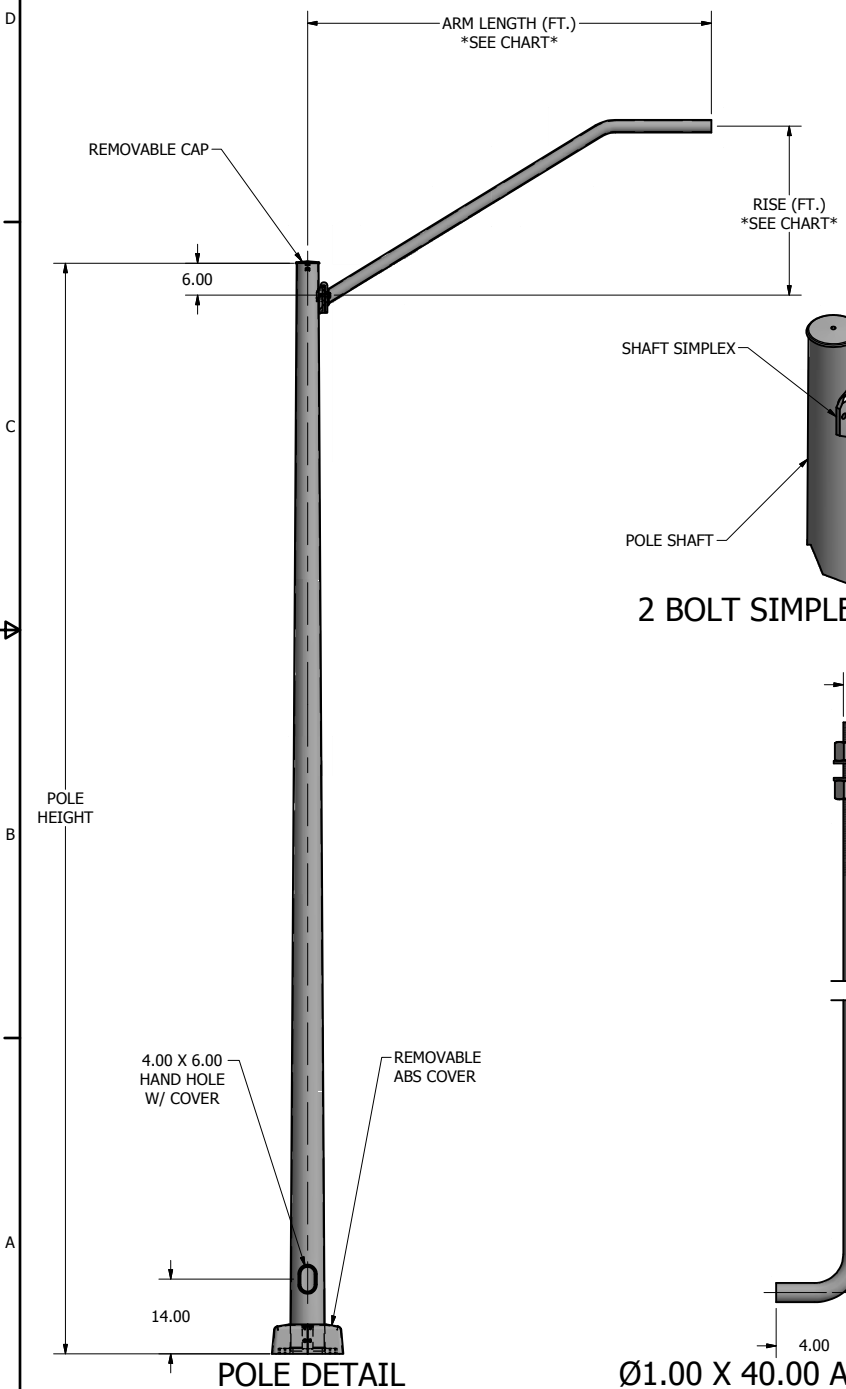

2 BOLT SIMPLEX DETAIL VIEW

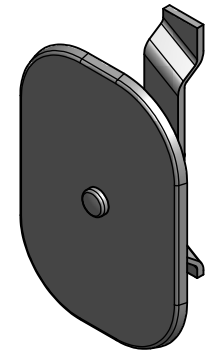

4.00 X 6.00 HAND HOLE COVER

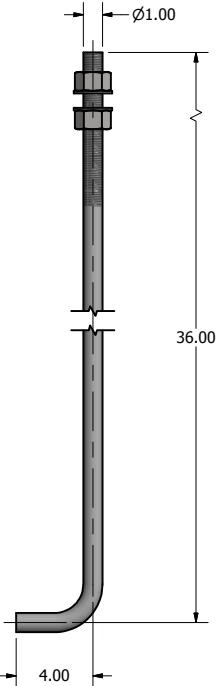

Ø1.00 X 40.00 ANCHOR BOLT

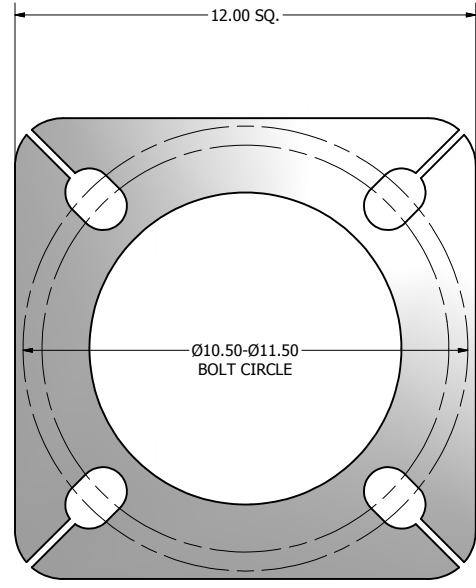

12.00 X 12.00 X 1.00 THK. BASE PLATE

23171 Groesbeck Hwy.
Warren, MI 48089
P: (586) 774-6105 | F: (586) 774-5706
www.generalstructuresinc.com



DRAWN: M. HARVALA	DATE: 2/18/2015
CHECKED:	DATE:
REVISION:	APPROVED:
QUOTE:	S.O.#
REF:	SCALE: NONE

